

Chapter 2

Getting Connected

Problems

- In Chapter 1 we saw networks consists of links interconnecting nodes. How to connect two nodes together?
- We also introduced the concept of “cloud” abstractions to represent a network without revealing its internal complexities. How to connect a host to a cloud?

Chapter Outline

- Perspectives on Connecting nodes
- Encoding
- Framing
- Error Detection
- Reliable Transmission
- Ethernet and Multiple Access Networks
- Wireless Networks

Chapter Goal

- Exploring different communication medium over which we can send data
- Understanding the issue of encoding bits onto transmission medium so that they can be understood by the receiving end
- Discussing the matter of delineating the sequence of bits transmitted over the link into complete messages that can be delivered to the end node
- Discussing different technique to detect transmission errors and take the appropriate action

Chapter Goal (contd.)

- Discussing the issue of making the links reliable in spite of transmission problems
- Introducing Media Access Control Problem
- Introducing Carrier Sense Multiple Access (CSMA) networks
- Introducing Wireless Networks with different available technologies and protocol

Perspectives on Connecting

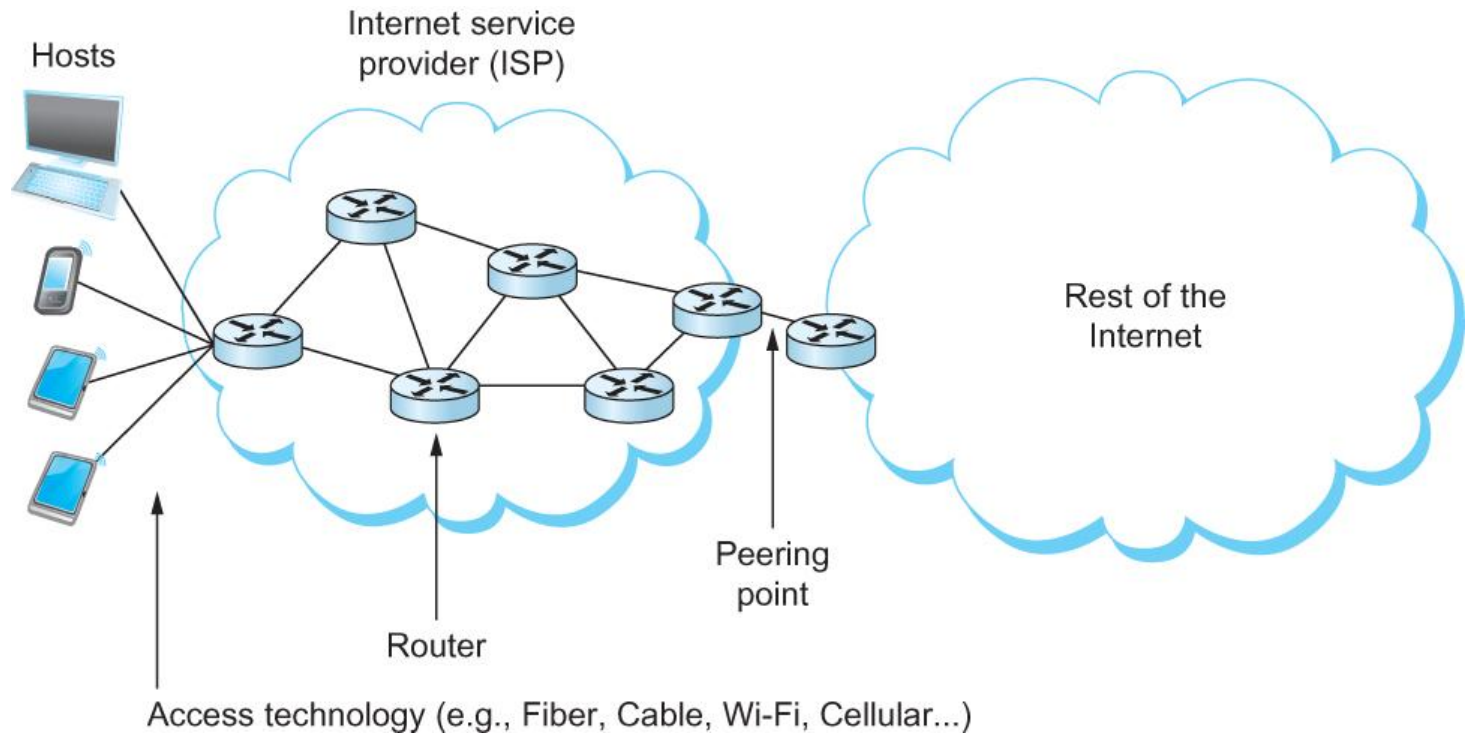

An end-user's view of the Internet

Link Capacity and Shannon-Hartley Theorem

- Gives the upper bound to the capacity of a link in terms of bits per second (bps) as a function of signal-to-noise ratio of the link measured in decibels (dB).
- $C = B \log_2(1+S/N)$
 - Where $B = 3300 - 300 = 3000\text{Hz}$, S is the signal power, N the average noise.
 - The signal to noise ratio (S/N) is measured in decibels is related to $\text{dB} = 10 \times \log_{10}(S/N)$. If there is 30dB of noise then $S/N = 1000$.
 - Now $C = 3000 \times \log_2(1001) = 30\text{kbps}$.
 - How can we get 56kbps?

Links

- All practical links rely on some sort of electromagnetic radiation propagating through a medium or, in some cases, through free space
- One way to characterize links, then, is by the medium they use
 - Typically copper wire in some form (as in Digital Subscriber Line (DSL) and coaxial cable),
 - Optical fiber (as in both commercial fiber-to-the home services and many long-distance links in the Internet's backbone), or
 - Air/free space (for wireless links)

Links

- Another important link characteristic is the *frequency*
 - Measured in hertz, with which the electromagnetic waves oscillate
- Distance between the adjacent pair of maxima or minima of a wave measured in meters is called *wavelength*
 - Speed of light divided by frequency gives the wavelength.
 - Frequency on a copper cable range from 300Hz to 3300Hz; Wavelength for 300Hz wave through copper is speed of light on a copper / frequency
 - $2/3 \times 3 \times 10^8 / 300 = 667 \times 10^3$ meters.
- Placing binary data on a signal is called *encoding*.
- Modulation involves modifying the signals in terms of their frequency, amplitude, and phase.

Links

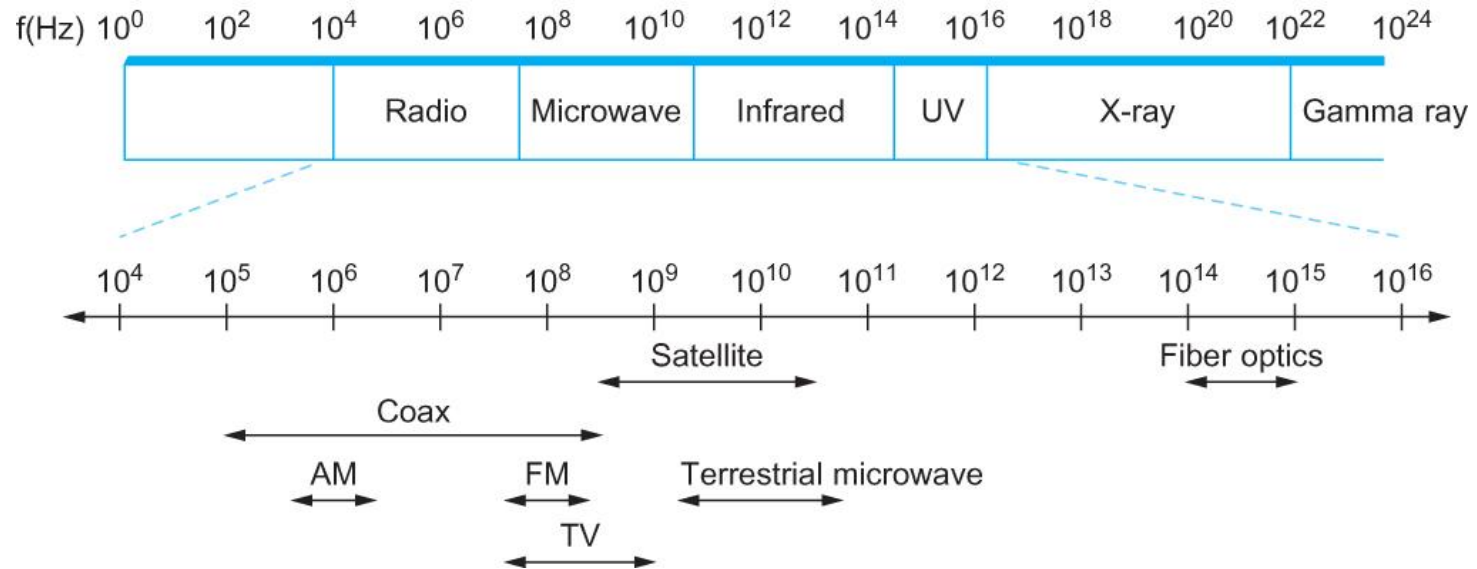

Electromagnetic spectrum

Links

Service	Bandwidth (typical)
Dial-up	28–56 kbps
ISDN	64–128 kbps
DSL	128 kbps–100 Mbps
CATV (cable TV)	1–40 Mbps
FTTH (fibre to the home)	50 Mbps–1 Gbps

Common services available to connect your home

Encoding

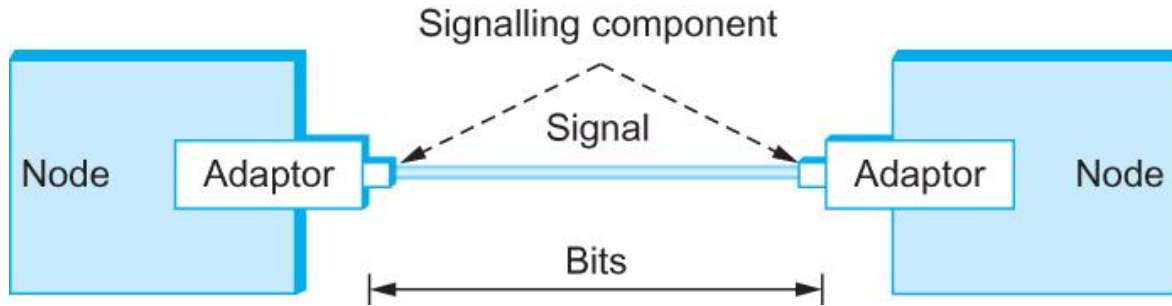

Signals travel between signaling components; bits flow between adaptors

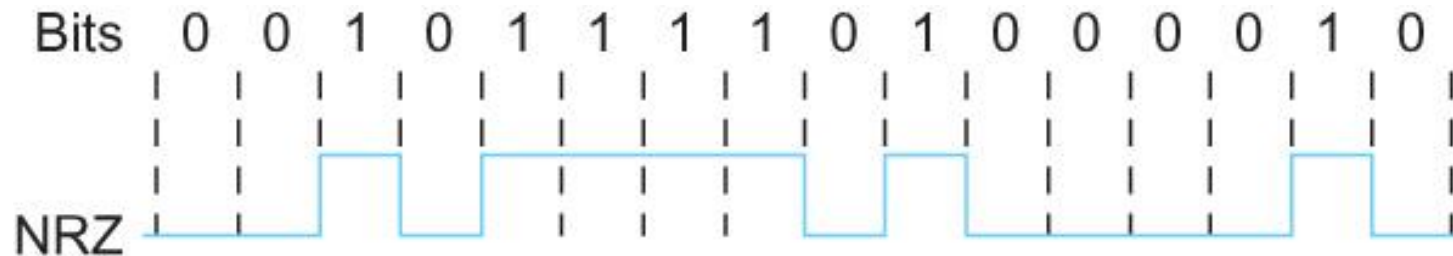

NRZ encoding of a bit stream

Encoding

- Problem with NRZ
 - Baseline wander
 - The receiver keeps an average of the signals it has seen so far
 - Uses the average to distinguish between low and high signal
 - When a signal is significantly low than the average, it is 0, else it is 1
 - Too many consecutive 0's and 1's cause this average to change, making it difficult to detect

Encoding

- Problem with NRZ
 - Clock recovery
 - Frequent transition from high to low or vice versa are necessary to enable clock recovery
 - Both the sending and decoding process is driven by a clock
 - Every clock cycle, the sender transmits a bit and the receiver recovers a bit
 - The sender and receiver have to be precisely synchronized

Encoding

- NRZI
 - Non Return to Zero Inverted
 - Sender makes a transition from the current signal to encode 1 and stay at the current signal to encode 0
 - Solves for consecutive 1's

Encoding

- Manchester encoding
 - Merging the clock with signal by transmitting Ex-OR of the NRZ encoded data and the clock
 - Clock is an internal signal that alternates from low to high, a low/high pair is considered as one clock cycle
 - In Manchester encoding
 - 0: low → high transition
 - 1: high → low transition

Encoding

- Problem with Manchester encoding
 - Doubles the rate at which the signal transitions are made on the link
 - Which means the receiver has half of the time to detect each pulse of the signal
 - The rate at which the signal changes is called the link's baud rate
 - In Manchester the bit rate is half the baud rate

Encoding

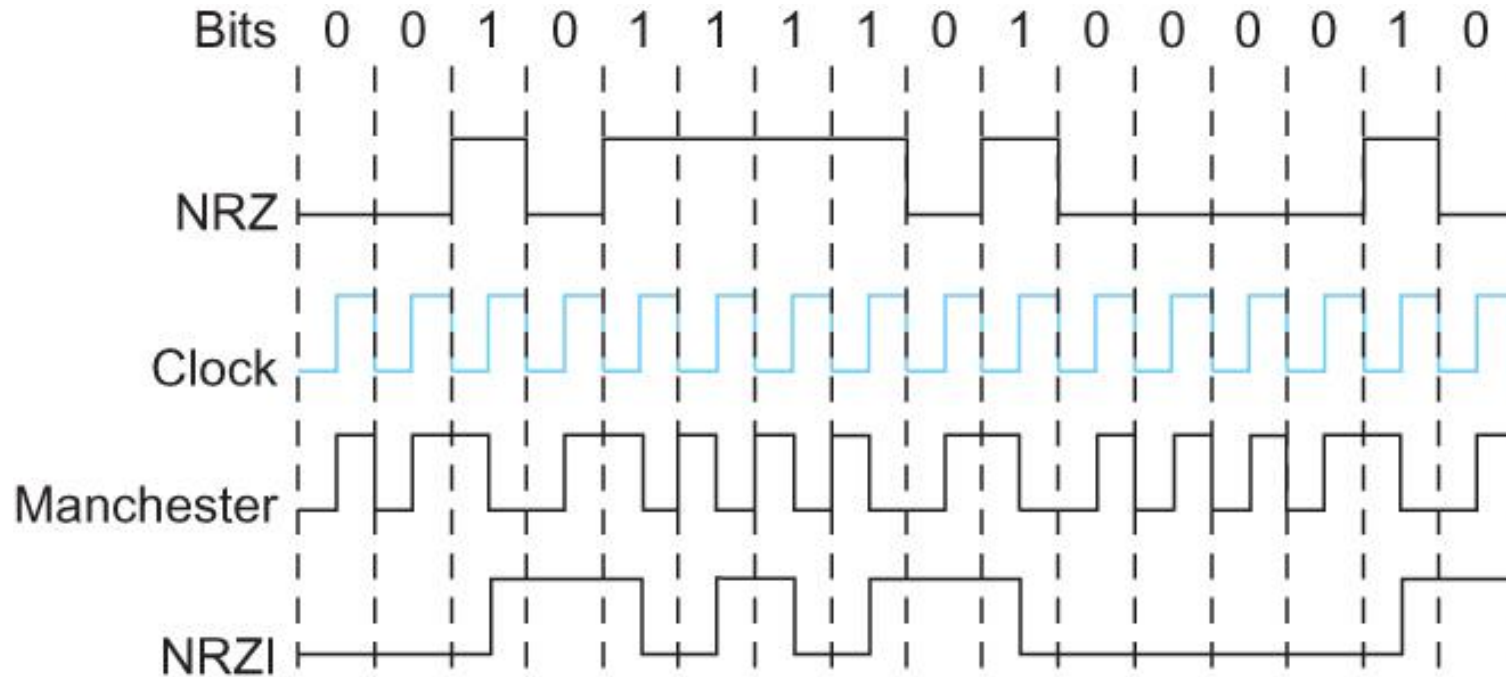

Different encoding strategies

Encoding

■ 4B/5B encoding

- Insert extra bits into bit stream so as to break up the long sequence of 0's and 1's
- Every 4-bits of actual data are encoded in a 5-bit code that is transmitted to the receiver
- 5-bit codes are selected in such a way that each one has no more than one leading 0(zero) and no more than two trailing 0's.
- No pair of 5-bit codes results in more than three consecutive 0's

Encoding

■ 4B/5B encoding

0000 → 11110

0001 → 01001

0010 → 10100

..

..

1111 → 11101

16 left

11111 – when the line is idle

00000 – when the line is dead

00100 – to mean halt

13 left : 7 invalid, 6 for various control signals

Framing

- We are focusing on packet-switched networks, which means that blocks of data (called *frames* at this level), not bit streams, are exchanged between nodes.
- It is the network adaptor that enables the nodes to exchange frames.

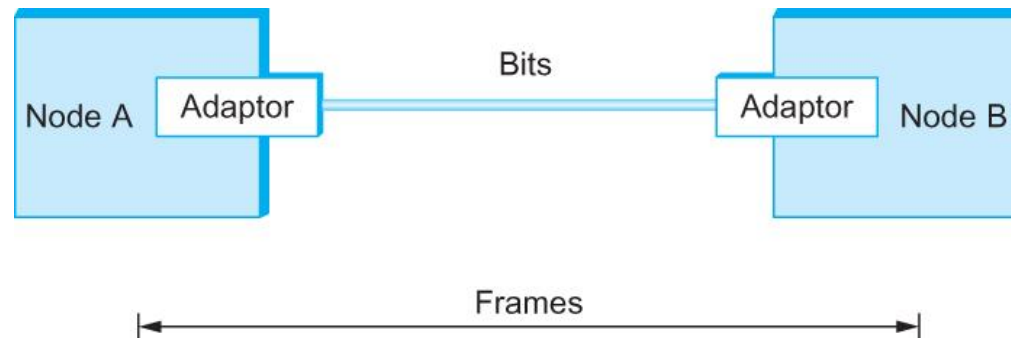

Bits flow between adaptors, frames between hosts

Framing

- When node A wishes to transmit a frame to node B, it tells its adaptor to transmit a frame from the node's memory. This results in a sequence of bits being sent over the link.
- The adaptor on node B then collects together the sequence of bits arriving on the link and deposits the corresponding frame in B's memory.
- Recognizing exactly what set of bits constitute a frame—that is, determining where the frame begins and ends—is the central challenge faced by the adaptor

Framing

- Byte-oriented Protocols
 - To view each frame as a collection of bytes (characters) rather than bits
 - BISYNC (Binary Synchronous Communication) Protocol
 - Developed by IBM (late 1960)
 - DDCMP (Digital Data Communication Protocol)
 - Used in DECNet

Framing

- BISYNC – sentinel approach
 - Frames transmitted beginning with leftmost field
 - Beginning of a frame is denoted by sending a special SYN (synchronize) character
 - Data portion of the frame is contained between special sentinel character STX (start of text) and ETX (end of text)
 - SOH : Start of Header
 - DLE : Data Link Escape
 - CRC: Cyclic Redundancy Check

Framing



BISYNC Frame Format

Framing

- Recent PPP which is commonly run over Internet links uses sentinel approach
 - Special start of text character denoted as Flag
 - 0 1 1 1 1 1 0
 - Address, control : default numbers
 - Protocol for demux : IP / IPX
 - Payload : negotiated (1500 bytes)
 - Checksum : for error detection

Framing

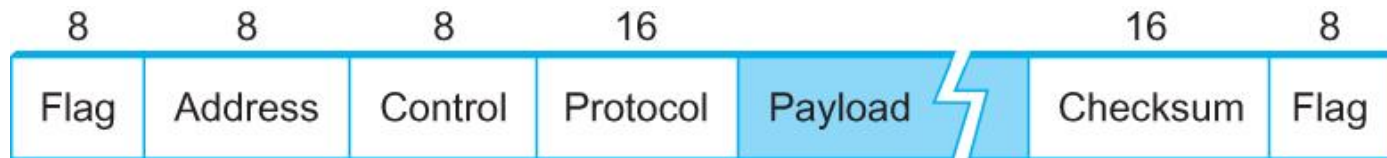

PPP Frame Format

Framing

- Byte-counting approach
 - DDCMP
 - *count* : how many bytes are contained in the frame body
 - If *count* is corrupted
 - Framing error

Framing



DDCMP Frame Format

Framing

- Bit-oriented Protocol
 - HDLC : High Level Data Link Control
 - Beginning and Ending Sequences

0 1 1 1 1 1 0



HDLC Frame Format

Framing

- HDLC Protocol
 - On the sending side, any time five consecutive 1's have been transmitted from the body of the message (i.e. excluding when the sender is trying to send the distinguished 0111110 sequence)
 - The sender inserts 0 before transmitting the next bit

Framing

- HDLC Protocol

- On the receiving side

- 5 consecutive 1's

- Next bit 0 : Stuffed, so discard it

- 1 : Either End of the frame marker

- Or Error has been introduced in the bitstream

- Look at the next bit

- If 0 (01111110) → End of the frame marker

- If 1 (01111111) → Error, discard the whole frame

- The receiver needs to wait for next
01111110 before it can start
receiving again

Error Detection

- Bit errors are introduced into frames
 - Because of electrical interference and thermal noises
- Detecting Error
- Correction Error
- Two approaches when the recipient detects an error
 - Notify the sender that the message was corrupted, so the sender can send again.
 - If the error is rare, then the retransmitted message will be error-free
 - Using some error correct detection and correction algorithm, the receiver reconstructs the message

Error Detection

- Common technique for detecting transmission error
 - CRC (Cyclic Redundancy Check)
 - Used in HDLC, DDCMP, CSMA/CD, Token Ring
 - Other approaches
 - Two Dimensional Parity (BISYNC)
 - Checksum (IP)

Error Detection

- Basic Idea of Error Detection
 - To add redundant information to a frame that can be used to determine if errors have been introduced
 - Imagine (Extreme Case)
 - Transmitting two complete copies of data
 - Identical → No error
 - Differ → Error
 - Poor Scheme ???
 - n bit message, n bit redundant information
 - Error can go undetected
 - In general, we can provide strong error detection technique
 - k redundant bits, n bits message, $k \ll n$
 - In Ethernet, a frame carrying up to 12,000 bits of data requires only 32-bit CRC

Error Detection

- Extra bits are redundant
 - They add no new information to the message
 - Derived from the original message using some algorithm
 - Both the sender and receiver know the algorithm

Sender

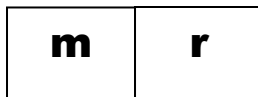

Receiver



Receiver computes r using m

If they match, no error

Two-dimensional parity

- Two-dimensional parity is exactly what the name suggests
- It is based on “simple” (one-dimensional) parity, which usually involves adding one extra bit to a 7-bit code to balance the number of 1s in the byte. For example,
 - Odd parity sets the eighth bit to 1 if needed to give an odd number of 1s in the byte, and
 - Even parity sets the eighth bit to 1 if needed to give an even number of 1s in the byte

Two-dimensional parity

- Two-dimensional parity does a similar calculation for each bit position across each of the bytes contained in the frame
- This results in an extra parity byte for the entire frame, in addition to a parity bit for each byte
- Two-dimensional parity catches all 1-, 2-, and 3-bit errors and most 4-bit errors

Two-dimensional parity

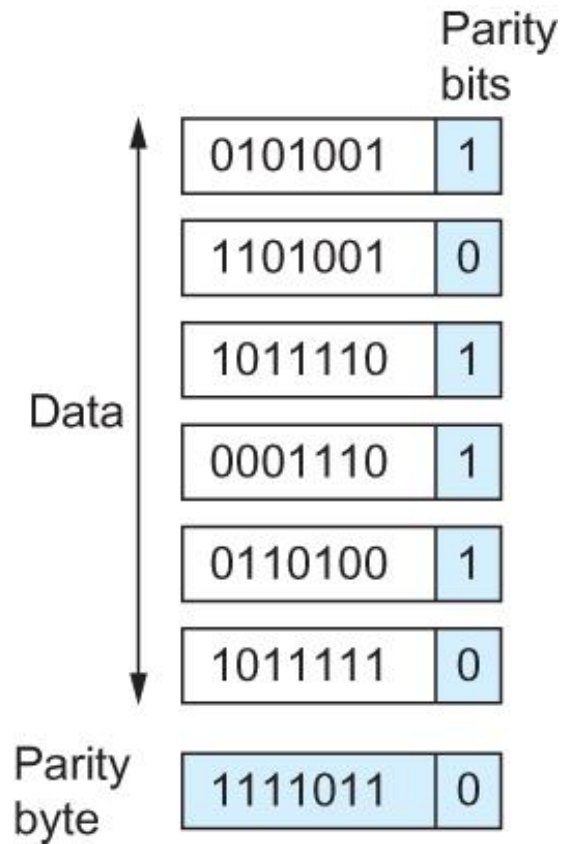

Two Dimensional Parity

Internet Checksum Algorithm

- Not used at the link level
- Add up all the words that are transmitted and then transmit the result of that sum
 - The result is called the checksum
- The receiver performs the same calculation on the received data and compares the result with the received checksum
- If any transmitted data, including the checksum itself, is corrupted, then the results will not match, so the receiver knows that an error occurred

Internet Checksum Algorithm

- Consider the data being checksummed as a sequence of 16-bit integers.
- Add them together using 16-bit ones complement arithmetic (explained next slide) and then take the ones complement of the result.
- That 16-bit number is the checksum

Internet Checksum Algorithm

- In ones complement arithmetic, a negative integer $-x$ is represented as the complement of x ;
 - Each bit of x is inverted.
- When adding numbers in ones complement arithmetic, a carryout from the most significant bit needs to be added to the result.

Internet Checksum Algorithm

- Consider, for example, the addition of -5 and -3 in ones complement arithmetic on 4-bit integers
 - $+5$ is 0101 , so -5 is 1010 ; $+3$ is 0011 , so -3 is 1100
- If we add 1010 and 1100 ignoring the carry, we get 0110
- In ones complement arithmetic, the fact that this operation caused a carry from the most significant bit causes us to increment the result, giving 0111 , which is the ones complement representation of -8 (obtained by inverting the bits in 1000), as we would expect

Cyclic Redundancy Check (CRC)

- Reduce the number of extra bits and maximize protection
- Given a bit string 110001 we can associate a polynomial on a single variable x for it.
 $1.x^5+1.x^4+0.x^3+0.x^2+0.x^1+1.x^0 = x^5+x^4+1$ and the degree is 5.
A k -bit frame has a maximum degree of $k-1$
- Let $M(x)$ be a message polynomial and $C(x)$ be a generator polynomial.

Cyclic Redundancy Check (CRC)

- Let $M(x)/C(x)$ leave a remainder of 0.
- When $M(x)$ is sent and $M'(x)$ is received we have $M'(x) = M(x) + E(x)$
- The receiver computes $M'(x)/C(x)$ and if the remainder is nonzero, then an error has occurred.
- The only thing the sender and the receiver should know is $C(x)$.

Cyclic Redundancy Check (CRC)

Polynomial Arithmetic Modulo 2

- Any polynomial $B(x)$ can be divided by a divisor polynomial $C(x)$ if $B(x)$ is of higher degree than $C(x)$.
- Any polynomial $B(x)$ can be divided once by a divisor polynomial $C(x)$ if $B(x)$ is of the same degree as $C(x)$.
- The remainder obtained when $B(x)$ is divided by $C(x)$ is obtained by subtracting $C(x)$ from $B(x)$.
- To subtract $C(x)$ from $B(x)$, we simply perform the exclusive-OR (XOR) operation on each pair of matching coefficients.

Cyclic Redundancy Check (CRC)

- Let $M(x)$ be a frame with m bits and let the generator polynomial have less than m bits say equal to r .
- Let r be the degree of $C(x)$. Append r zero bits to the low-order end of the frame, so it now contains $m+r$ bits and corresponds to the polynomial $x^rM(x)$.

Cyclic Redundancy Check (CRC)

- Divide the bit string corresponding to $x^r M(x)$ by the bit string corresponding to $C(x)$ using modulo 2 division.
- Subtract the remainder (which is always r or fewer bits) from the string corresponding to $x^r M(x)$ using modulo 2 subtraction (addition and subtraction are the same in modulo 2).
- The result is the checksummed frame to be transmitted. Call it polynomial $M'(x)$.

Cyclic Redundancy Check (CRC)

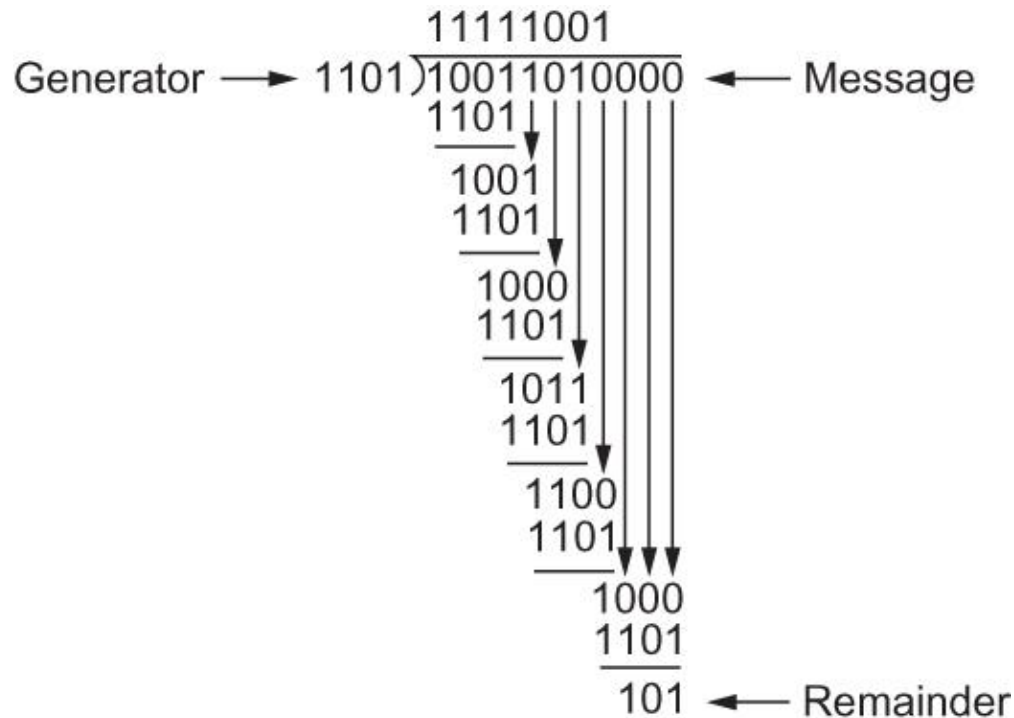

CRC Calculation using Polynomial Long Division

Cyclic Redundancy Check (CRC)

- Properties of Generator Polynomial
 - Let $P(x)$ represent what the sender sent and $P(x) + E(x)$ is the received string. A 1 in $E(x)$ represents that in the corresponding position in $P(x)$ the message the bit is flipped.
 - We know that $P(x)/C(x)$ leaves a remainder of 0, but if $E(x)/C(x)$ leaves a remainder of 0, then either $E(x) = 0$ or $C(x)$ is factor of $E(x)$.
 - When $C(x)$ is a factor of $E(x)$ we have problem; errors go unnoticed.
 - If there is a single bit error then $E(x) = x^i$, where i determines the bit in error. If $C(x)$ contains two or more terms it will never divide $E(x)$, so all single bit errors will be detected.

Cyclic Redundancy Check (CRC)

- Properties of Generator Polynomial
 - In general, it is possible to prove that the following types of errors can be detected by a $C(x)$ with the stated properties
 - All single-bit errors, as long as the x^k and x^0 terms have nonzero coefficients.
 - All double-bit errors, as long as $C(x)$ has a factor with at least three terms.
 - Any odd number of errors, as long as $C(x)$ contains the factor $(x+1)$.
 - Any “burst” error (i.e., sequence of consecutive error bits) for which the length of the burst is less than k bits. (Most burst errors of larger than k bits can also be detected.)

Cyclic Redundancy Check (CRC)

- Six generator polynomials that have become international standards are:
 - CRC-8 = x^8+x^2+x+1
 - CRC-10 = $x^{10}+x^9+x^5+x^4+x+1$
 - CRC-12 = $x^{12}+x^{11}+x^3+x^2+x+1$
 - CRC-16 = $x^{16}+x^{15}+x^2+1$
 - CRC-CCITT = $x^{16}+x^{12}+x^5+1$
 - CRC-32 =
 $x^{32}+x^{26}+x^{23}+x^{22}+x^{16}+x^{12}+x^{11}+x^{10}+x^8+x^7+x^5+x^4+x^2+x+1$

Reliable Transmission

- CRC is used to detect errors.
- Some error codes are strong enough to correct errors.
- The overhead is typically too high.
- Corrupt frames must be discarded.
- A link-level protocol that wants to deliver frames reliably must recover from these discarded frames.
- This is accomplished using a combination of two fundamental mechanisms
 - Acknowledgements and Timeouts

Reliable Transmission

- An *acknowledgement* (ACK for short) is a small control frame that a protocol sends back to its peer saying that it has received the earlier frame.
 - A control frame is a frame with header only (no data).
- The receipt of an *acknowledgement* indicates to the sender of the original frame that its frame was successfully delivered.

Reliable Transmission

- If the sender does not receive an *acknowledgment* after a reasonable amount of time, then it retransmits the original frame.
- The action of waiting a reasonable amount of time is called a *timeout*.
- The general strategy of using *acknowledgements* and *timeouts* to implement reliable delivery is sometimes called Automatic Repeat reQuest (ARQ).

Stop and Wait Protocol

- Idea of stop-and-wait protocol is straightforward
 - After transmitting one frame, the sender waits for an acknowledgement before transmitting the next frame.
 - If the acknowledgement does not arrive after a certain period of time, the sender times out and retransmits the original frame

Stop and Wait Protocol

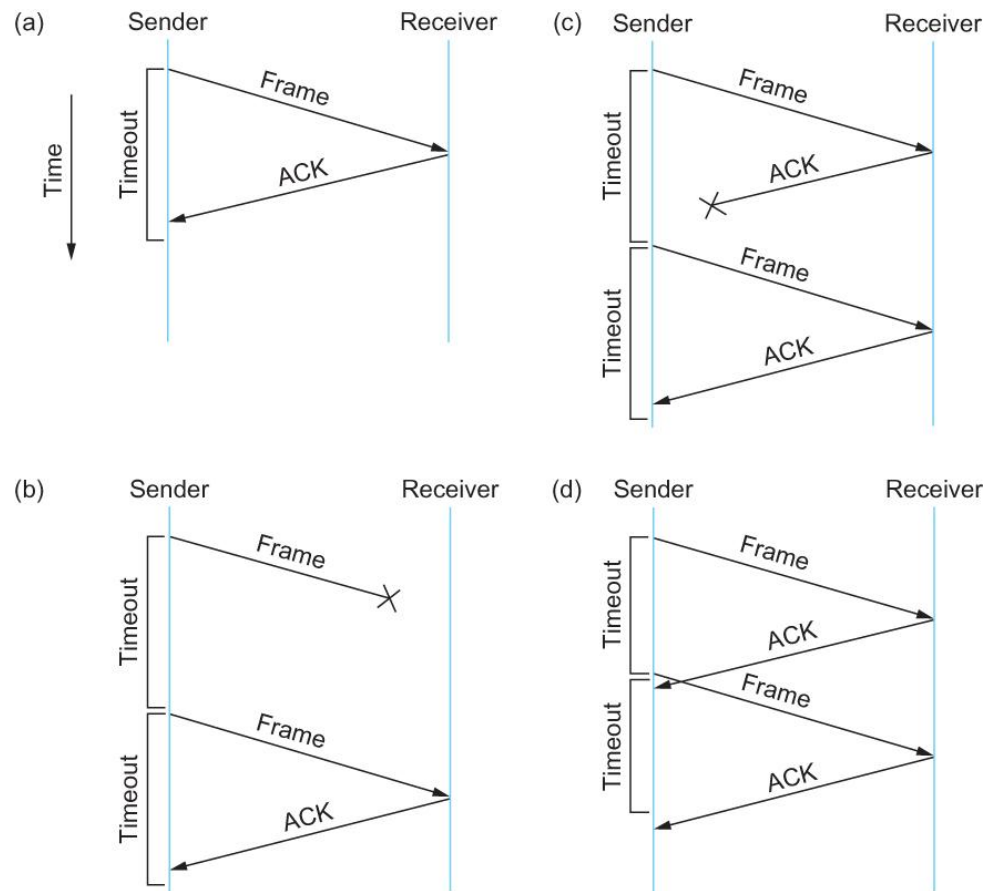

Timeline showing four different scenarios for the stop-and-wait algorithm.

(a) The ACK is received before the timer expires; (b) the original frame is lost; (c) the ACK is lost; (d) the timeout fires too soon

Stop and Wait Protocol

- If the acknowledgment is lost or delayed in arriving
 - The sender times out and retransmits the original frame, but the receiver will think that it is the next frame since it has correctly received and acknowledged the first frame
 - As a result, duplicate copies of frames will be delivered
- How to solve this
 - Use 1 bit sequence number (0 or 1)
 - When the sender retransmits frame 0, the receiver can determine that it is seeing a second copy of frame 0 rather than the first copy of frame 1 and therefore can ignore it (the receiver still acknowledges it, in case the first acknowledgement was lost)

Stop and Wait Protocol

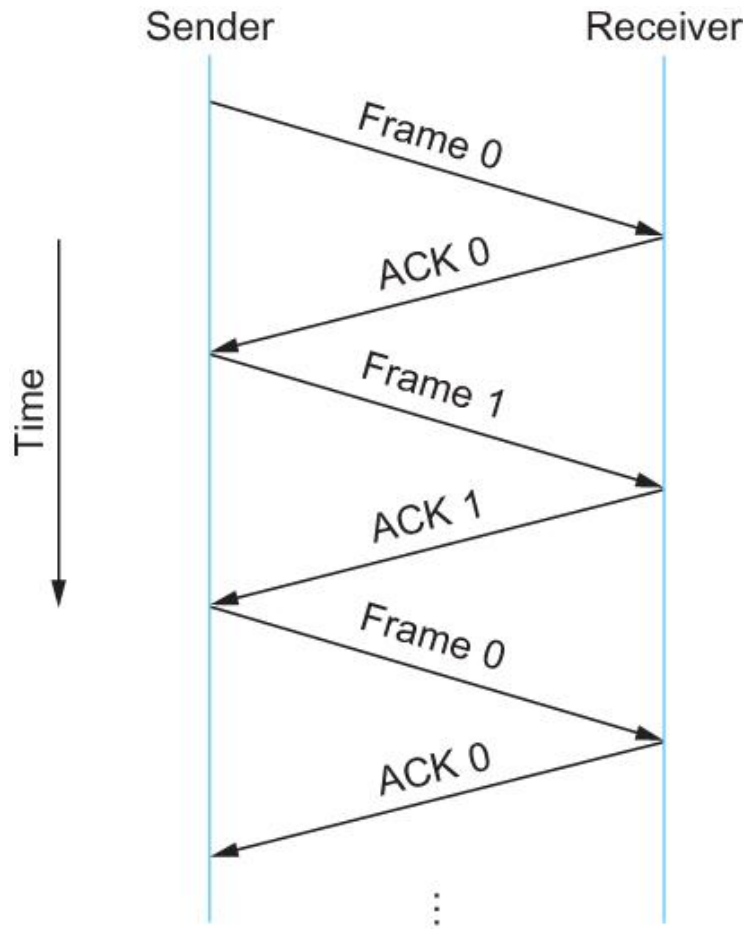

Timeline for stop-and-wait with 1-bit sequence number

Stop and Wait Protocol

- The sender has only one outstanding frame on the link at a time
 - This may be far below the link's capacity
- Consider a 1.5 Mbps link with a 45 ms RTT
 - The link has a delay \times bandwidth product of 67.5 Kb or approximately 8 KB
 - Since the sender can send only one frame per RTT and assuming a frame size of 1 KB
 - Maximum Sending rate
 - $\text{Bits per frame} \div \text{Time per frame} = 1024 \times 8 \div 0.045 = 182 \text{ Kbps}$
Or about one-eighth of the link's capacity
 - To use the link fully, then sender should transmit up to eight frames before having to wait for an acknowledgement

Sliding Window Protocol

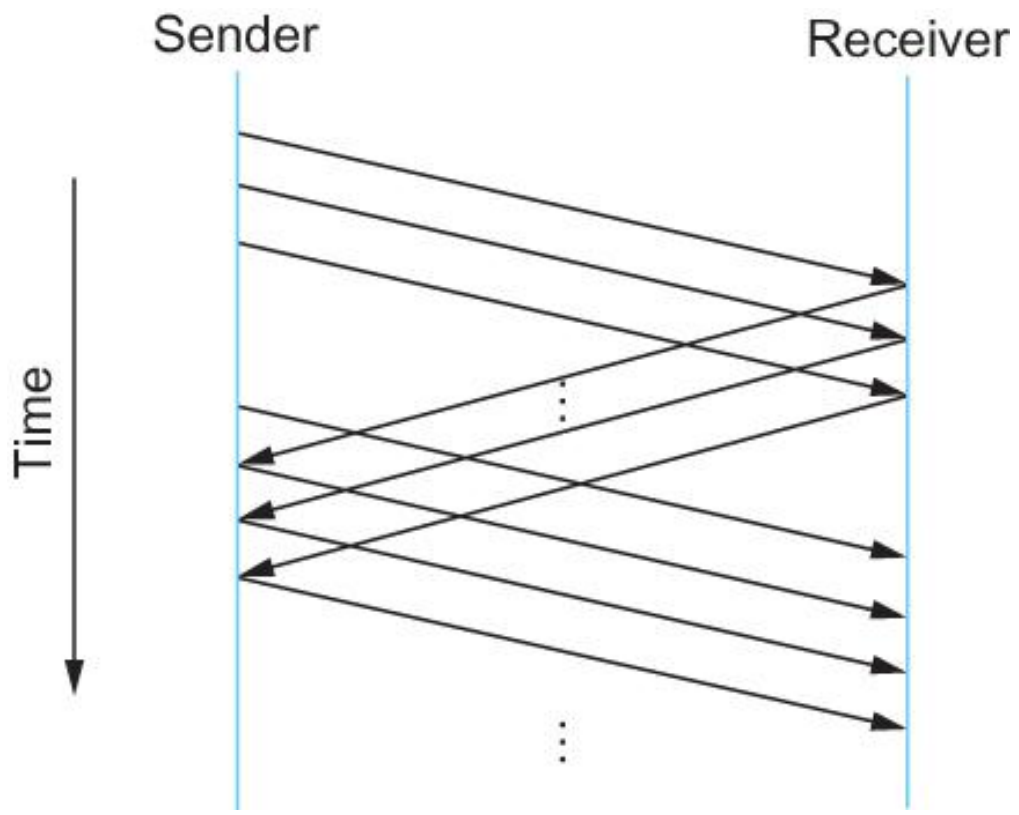

Timeline for Sliding Window Protocol

Sliding Window Protocol

- Sender assigns a sequence number denoted as SeqNum to each frame.
 - Assume it can grow infinitely large
- Sender maintains three variables
 - Sending Window Size (SWS)
 - Upper bound on the number of outstanding (unacknowledged) frames that the sender can transmit
 - Last Acknowledgement Received (LAR)
 - Sequence number of the last acknowledgement received
 - Last Frame Sent (LFS)
 - Sequence number of the last frame sent

Sliding Window Protocol

- Sender also maintains the following invariant
 $LFS - LAR \leq SWS$

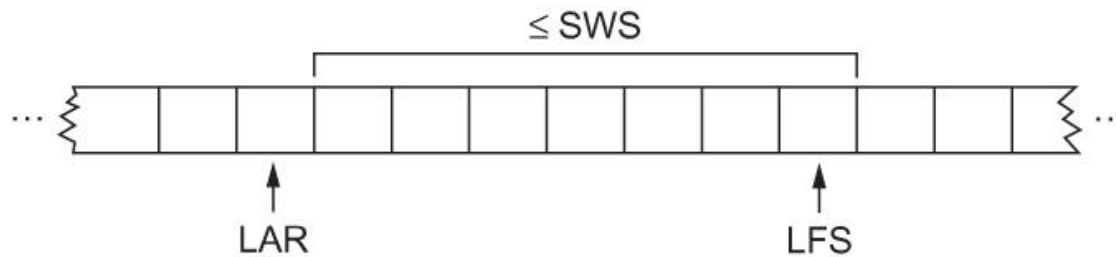

Sliding Window on Sender

Sliding Window Protocol

- When an acknowledgement arrives
 - the sender moves LAR to right, thereby allowing the sender to transmit another frame
- Also the sender associates a timer with each frame it transmits
 - It retransmits the frame if the timer expires before the ACK is received
- Note that the sender has to be willing to buffer up to SWS frames
 - WHY?

Sliding Window Protocol

- Receiver maintains three variables
 - Receiving Window Size (RWS)
 - Upper bound on the number of out-of-order frames that the receiver is willing to accept
 - Largest Acceptable Frame (LAF)
 - Sequence number of the largest acceptable frame
 - Last Frame Received (LFR)
 - Sequence number of the last frame received

Sliding Window Protocol

- Receiver also maintains the following invariant
 $LAF - LFR \leq RWS$

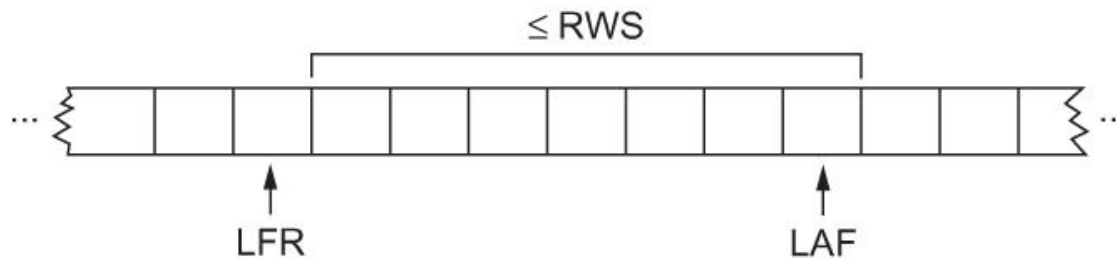

Sliding Window on Receiver

Sliding Window Protocol

- When a frame with sequence number SeqNum arrives, what does the receiver do?
 - If $\text{SeqNum} \leq \text{LFR}$ or $\text{SeqNum} > \text{LAF}$
 - Discard it (the frame is outside the receiver window)
 - If $\text{LFR} < \text{SeqNum} \leq \text{LAF}$
 - Accept it
 - Now the receiver needs to decide whether or not to send an ACK

Sliding Window Protocol

- Let SeqNumToAck
 - Denote the largest sequence number not yet acknowledged, such that all frames with sequence number less than or equal to SeqNumToAck have been received
- The receiver acknowledges the receipt of SeqNumToAck even if high-numbered packets have been received
 - This acknowledgement is said to be cumulative.
- The receiver then sets
 - $\text{LFR} = \text{SeqNumToAck}$ and adjusts
 - $\text{LAF} = \text{LFR} + \text{RWS}$

Sliding Window Protocol

For example, suppose $LFR = 5$ and $RWS = 4$
(i.e. the last ACK that the receiver sent was for seq. no. 5)
⇒ $LAF = 9$

If frames 7 and 8 arrive, they will be buffered because they are within the receiver window

But no ACK will be sent since frame 6 is yet to arrive

Frames 7 and 8 are out of order

Frame 6 arrives (it is late because it was lost first time and had to be retransmitted)

Now Receiver Acknowledges Frame 8
and bumps LFR to 8
and LAF to 12

Issues with Sliding Window Protocol

- When timeout occurs, the amount of data in transit decreases
 - Since the sender is unable to advance its window
- When the packet loss occurs, this scheme is no longer keeping the pipe full
 - The longer it takes to notice that a packet loss has occurred, the more severe the problem becomes
- How to improve this
 - Negative Acknowledgement (NAK)
 - Additional Acknowledgement
 - Selective Acknowledgement

Issues with Sliding Window Protocol

- Negative Acknowledgement (NAK)
 - Receiver sends NAK for frame 6 when frame 7 arrive (in the previous example)
 - However this is unnecessary since sender's timeout mechanism will be sufficient to catch the situation
- Additional Acknowledgement
 - Receiver sends additional ACK for frame 5 when frame 7 arrives
 - Sender uses duplicate ACK as a clue for frame loss
- Selective Acknowledgement
 - Receiver will acknowledge exactly those frames it has received, rather than the highest number frames
 - Receiver will acknowledge frames 7 and 8
 - Sender knows frame 6 is lost
 - Sender can keep the pipe full (additional complexity)

Issues with Sliding Window Protocol

How to select the window size

- SWS is easy to compute
 - Delay \times Bandwidth
- RWS can be anything
 - Two common setting
 - RWS = 1

No buffer at the receiver for frames that arrive out of order

- RWS = SWS

The receiver can buffer frames that the sender transmits

It does not make any sense to keep RWS > SWS

WHY?

Issues with Sliding Window Protocol

- Finite Sequence Number
 - Frame sequence number is specified in the header field
 - Finite size
 - 3 bit: eight possible sequence number: 0, 1, 2, 3, 4, 5, 6, 7
 - It is necessary to wrap around

Issues with Sliding Window Protocol

- How to distinguish between different incarnations of the same sequence number?
 - Number of possible sequence number must be larger than the number of outstanding frames allowed
 - Stop and Wait: One outstanding frame
 - 2 distinct sequence number (0 and 1)
 - Let `MaxSeqNum` be the number of available sequence numbers
 - $SWS + 1 \leq \text{MaxSeqNum}$
 - Is this sufficient?

Issues with Sliding Window Protocol

$SWS + 1 \leq \text{MaxSeqNum}$

- Is this sufficient?
 - Depends on RWS
 - If $RWS = 1$, then sufficient
 - If $RWS = SWS$, then not good enough
- For example, we have eight sequence numbers

0, 1, 2, 3, 4, 5, 6, 7

$RWS = SWS = 7$

Sender sends 0, 1, ..., 6

Receiver receives 0, 1, ..., 6

Receiver acknowledges 0, 1, ..., 6

ACK (0, 1, ..., 6) are lost

Sender retransmits 0, 1, ..., 6

Receiver is expecting 7, 0, ..., 5

Issues with Sliding Window Protocol

To avoid this,

If $RWS = SWS$

$SWS < (MaxSeqNum + 1)/2$

Issues with Sliding Window Protocol

- Serves three different roles
 - Reliable
 - Preserve the order
 - Each frame has a sequence number
 - The receiver makes sure that it does not pass a frame up to the next higher-level protocol until it has already passed up all frames with a smaller sequence number
 - Frame control
 - Receiver is able to throttle the sender
 - Keeps the sender from overrunning the receiver
 - From transmitting more data than the receiver is able to process

Ethernet

- Most successful local area networking technology of last 20 years.
- Developed in the mid-1970s by researchers at the Xerox Palo Alto Research Centers (PARC).
- Uses CSMA/CD technology
 - Carrier Sense Multiple Access with Collision Detection.
 - A set of nodes send and receive frames over a shared link.
 - Carrier sense means that all nodes can distinguish between an idle and a busy link.
 - Collision detection means that a node listens as it transmits and can therefore detect when a frame it is transmitting has collided with a frame transmitted by another node.

Ethernet

- Uses ALOHA (packet radio network) as the root protocol
 - Developed at the University of Hawaii to support communication across the Hawaiian Islands.
 - For ALOHA the medium was atmosphere, for Ethernet the medium is a coax cable.
- DEC and Intel joined Xerox to define a 10-Mbps Ethernet standard in 1978.
- This standard formed the basis for IEEE standard 802.3
- More recently 802.3 has been extended to include a 100-Mbps version called Fast Ethernet and a 1000-Mbps version called Gigabit Ethernet.

Ethernet

- An Ethernet segment is implemented on a coaxial cable of up to 500 m.
 - This cable is similar to the type used for cable TV except that it typically has an impedance of 50 ohms instead of cable TV's 75 ohms.
- Hosts connect to an Ethernet segment by tapping into it.
- A transceiver (a small device directly attached to the tap) detects when the line is idle and drives signal when the host is transmitting.
- The transceiver also receives incoming signal.
- The transceiver is connected to an Ethernet adaptor which is plugged into the host.
- The protocol is implemented on the adaptor.

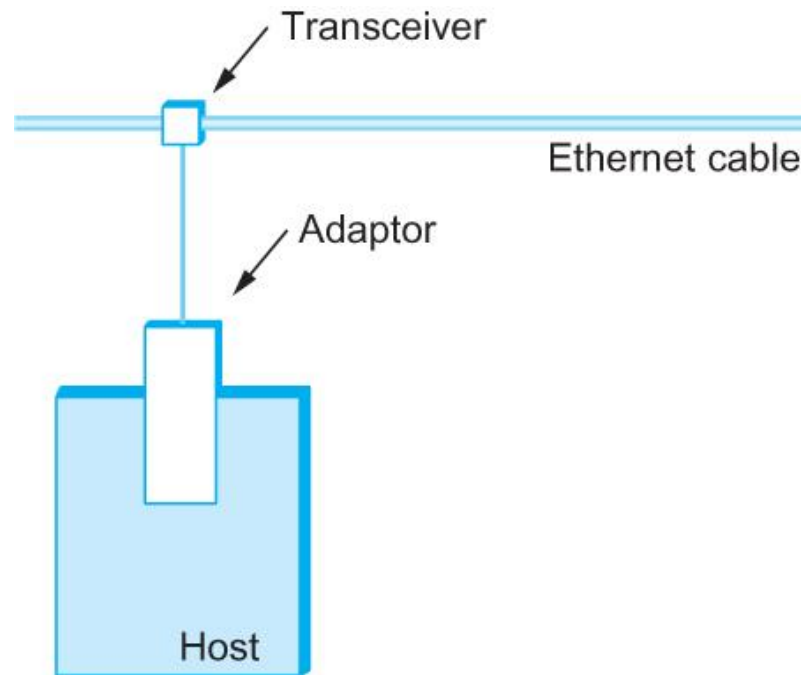

Ethernet transceiver and adaptor

Ethernet

- Multiple Ethernet segments can be joined together by *repeaters*.
- A *repeater* is a device that forwards digital signals.
- No more than four repeaters may be positioned between any pair of hosts.
 - An Ethernet has a total reach of only 2500 m.

Ethernet

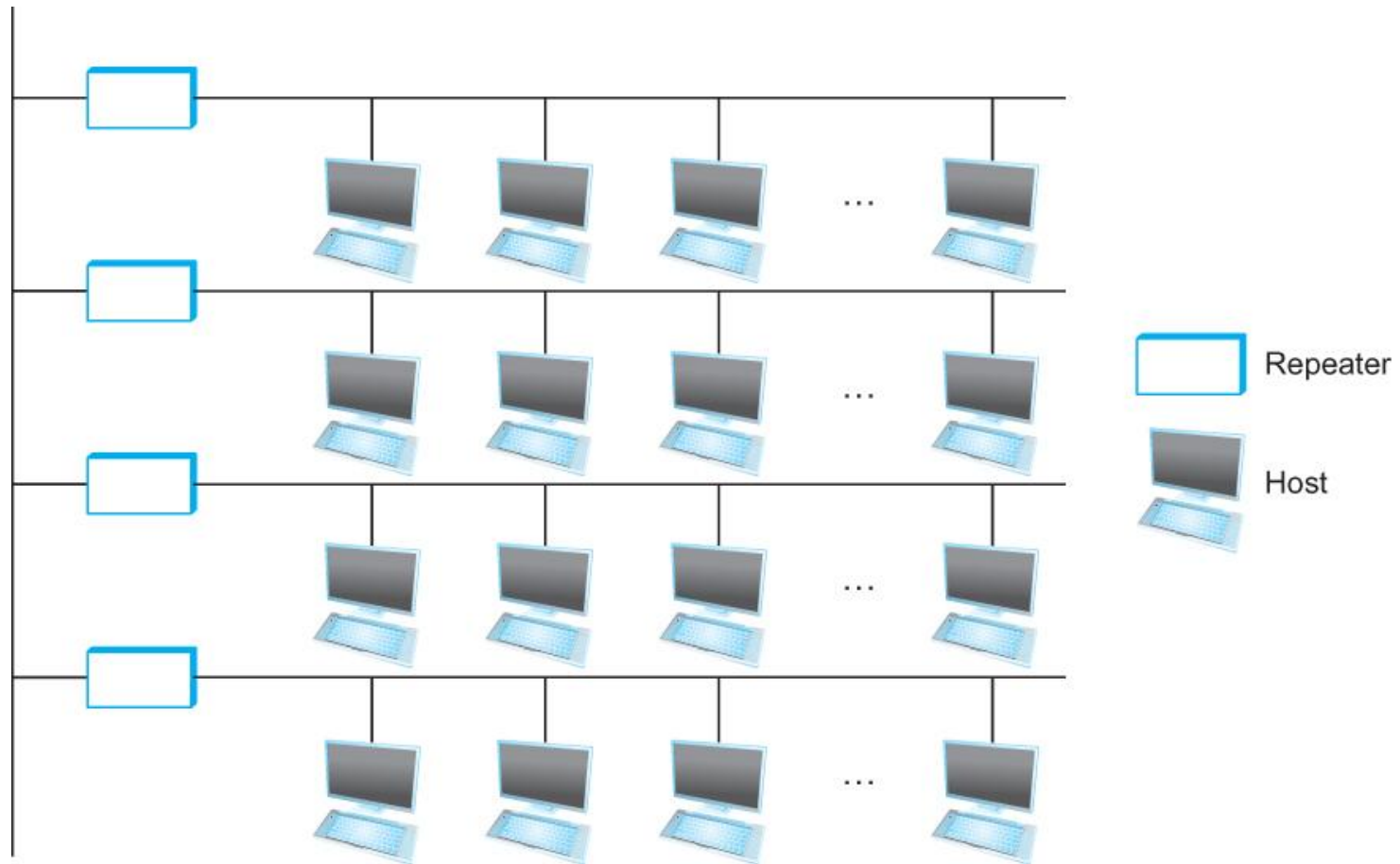

Ethernet repeater

Ethernet

- Any signal placed on the Ethernet by a host is broadcast over the entire network
 - Signal is propagated in both directions.
 - Repeaters forward the signal on all outgoing segments.
 - Terminators attached to the end of each segment absorb the signal.

- Ethernet uses Manchester encoding scheme.

Ethernet

- New Technologies in Ethernet
 - Instead of using coax cable, an Ethernet can be constructed from a thinner cable known as 10Base2 (the original was 10Base5)
 - 10 means the network operates at 10 Mbps
 - Base means the cable is used in a baseband system
 - 2 means that a given segment can be no longer than 200 m

Ethernet

- New Technologies in Ethernet
 - Another cable technology is 10BaseT
 - T stands for twisted pair
 - Limited to 100 m in length
 - With 10BaseT, the common configuration is to have several point to point segments coming out of a multiway repeater, called *Hub*

Ethernet

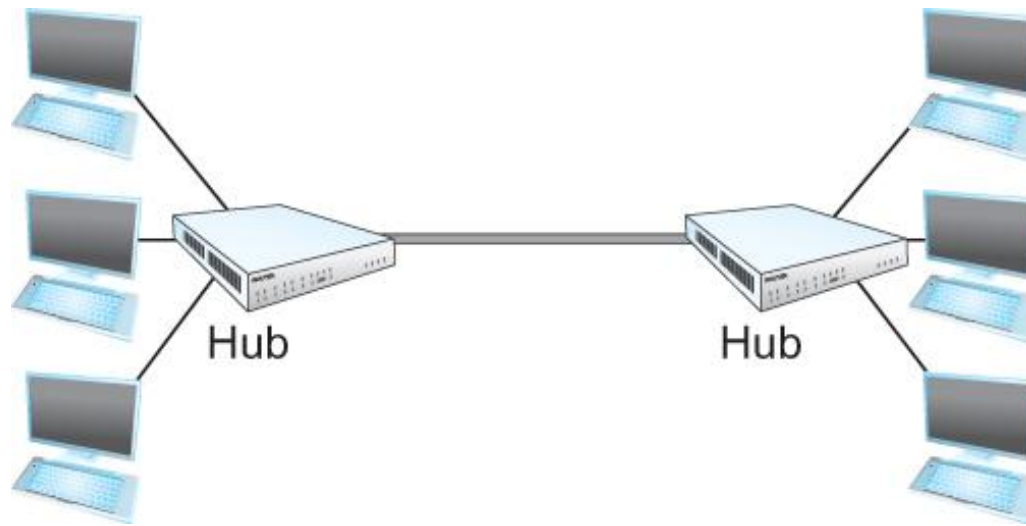

Ethernet Hub

Access Protocol for Ethernet

- The algorithm is commonly called Ethernet's Media Access Control (MAC).
 - It is implemented in Hardware on the network adaptor.
- Frame format
 - Preamble (64bit): allows the receiver to synchronize with the signal (sequence of alternating 0s and 1s).
 - Host and Destination Address (48bit each).
 - Packet type (16bit): acts as demux key to identify the higher level protocol.
 - Data (up to 1500 bytes)
 - Minimally a frame must contain at least 46 bytes of data.
 - Frame must be long enough to detect collision.
 - CRC (32bit)

Ethernet Frame

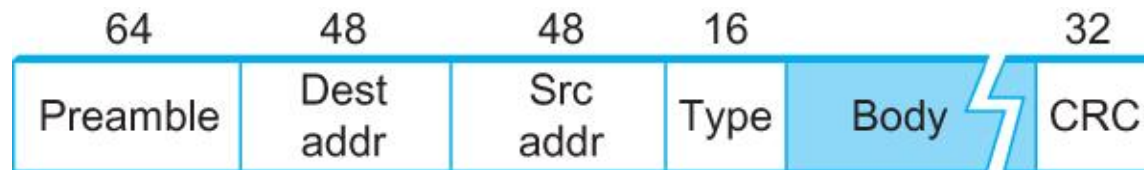

Ethernet Frame Format

Ethernet Addresses

- Each host on an Ethernet (in fact, every Ethernet host in the world) has a unique Ethernet Address.
- The address belongs to the adaptor, not the host.
 - It is usually burnt into ROM.
- Ethernet addresses are typically printed in a human readable format
 - As a sequence of six numbers separated by colons.
 - Each number corresponds to 1 byte of the 6 byte address and is given by a pair of hexadecimal digits, one for each of the 4-bit nibbles in the byte
 - Leading 0s are dropped.
 - For example, 8:0:2b:e4:b1:2 is
 - 00001000 00000000 00101011 11100100 10110001 00000010

Ethernet Addresses

- To ensure that every adaptor gets a unique address, each manufacturer of Ethernet devices is allocated a different prefix that must be prepended to the address on every adaptor they build
 - AMD has been assigned the 24bit prefix 8:0:20

Ethernet Addresses

- Each frame transmitted on an Ethernet is received by every adaptor connected to that Ethernet.
- Each adaptor recognizes those frames addressed to its address and passes only those frames on to the host.
- In addition, to *unicast* address, an Ethernet address consisting of all 1s is treated as a *broadcast* address.
 - All adaptors pass frames addressed to the *broadcast* address up to the host.
- Similarly, an address that has the first bit set to 1 but is not the *broadcast* address is called a *multicast* address.
 - A given host can program its adaptor to accept some set of *multicast* addresses.

Ethernet Addresses

- To summarize, an Ethernet adaptor receives all frames and accepts
 - Frames addressed to its own address
 - Frames addressed to the broadcast address
 - Frames addressed to a multicast address if it has been instructed

Ethernet Transmitter Algorithm

- When the adaptor has a frame to send and the line is idle, it transmits the frame immediately.
 - The upper bound of 1500 bytes in the message means that the adaptor can occupy the line for a fixed length of time.
- When the adaptor has a frame to send and the line is busy, it waits for the line to go idle and then transmits immediately.
- The Ethernet is said to be 1-persistent protocol because an adaptor with a frame to send transmits with probability 1 whenever a busy line goes idle.

Ethernet Transmitter Algorithm

- Since there is no centralized control it is possible for two (or more) adaptors to begin transmitting at the same time,
 - Either because both found the line to be idle,
 - Or, both had been waiting for a busy line to become idle.
- When this happens, the two (or more) frames are said to be *collide* on the network.

Ethernet Transmitter Algorithm

- Since Ethernet supports collision detection, each sender is able to determine that a collision is in progress.
- At the moment an adaptor detects that its frame is colliding with another, it first makes sure to transmit a 32-bit jamming sequence and then stops transmission.
 - Thus, a transmitter will minimally send 96 bits in the case of collision
 - 64-bit preamble + 32-bit jamming sequence

Ethernet Transmitter Algorithm

- One way that an adaptor will send only 96 bit (called a *runt frame*) is if the two hosts are close to each other.
- Had they been farther apart,
 - They would have had to transmit longer, and thus send more bits, before detecting the collision.

Ethernet Transmitter Algorithm

- The worst case scenario happens when the two hosts are at opposite ends of the Ethernet.
- To know for sure that the frame its just sent did not collide with another frame, the transmitter may need to send as many as 512 bits.
 - Every Ethernet frame must be at least 512 bits (64 bytes) long.
 - 14 bytes of header + 46 bytes of data + 4 bytes of CRC

Ethernet Transmitter Algorithm

- Why 512 bits?
 - Why is its length limited to 2500 m?
- The farther apart two nodes are, the longer it takes for a frame sent by one to reach the other, and the network is vulnerable to collision during this time

Ethernet Transmitter Algorithm

- A begins transmitting a frame at time t
- d denotes the one link latency
- The first bit of A's frame arrives at B at time $t + d$
- Suppose an instant before host A's frame arrives, host B begins to transmit its own frame
- B's frame will immediately collide with A's frame and this collision will be detected by host B
- Host B will send the 32-bit jamming sequence
- Host A will not know that the collision occurred until B's frame reaches it, which will happen at $t + 2 * d$
- Host A must continue to transmit until this time in order to detect the collision
 - Host A must transmit for $2 * d$ to be sure that it detects all possible collisions

Ethernet Transmitter Algorithm

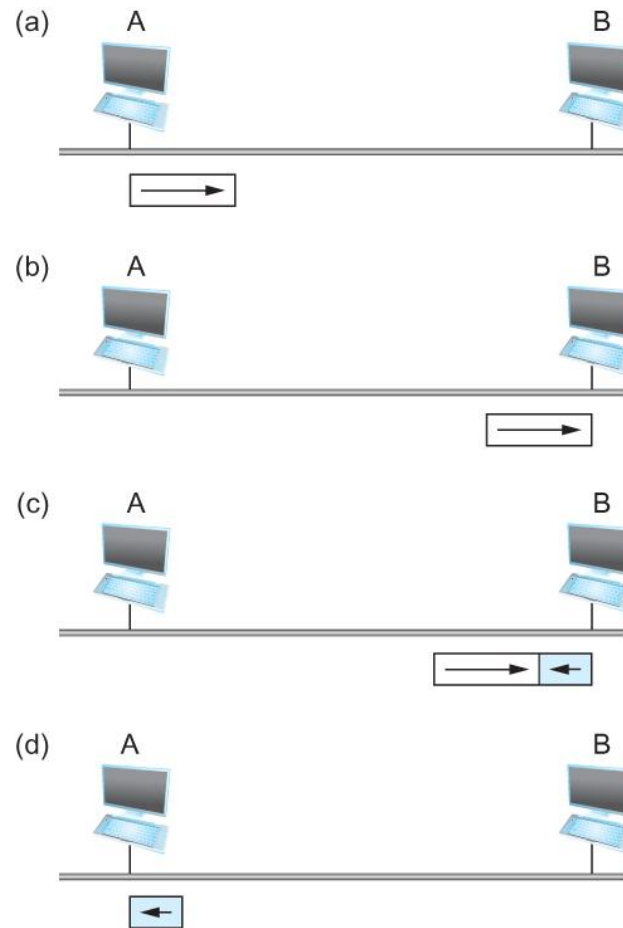

Worst-case scenario: (a) A sends a frame at time t ; (b) A's frame arrives at B at time $t + d$; (c) B begins transmitting at time $t + d$ and collides with A's frame; (d) B's runt (32-bit) frame arrives at A at time $t + 2d$.

Ethernet Transmitter Algorithm

- Consider that a maximally configured Ethernet is 2500 m long, and there may be up to four repeaters between any two hosts, the round trip delay has been determined to be $51.2 \mu\text{s}$
 - Which on 10 Mbps Ethernet corresponds to 512 bits
- The other way to look at this situation,
 - We need to limit the Ethernet's maximum latency to a fairly small value ($51.2 \mu\text{s}$) for the access algorithm to work
 - Hence the maximum length for the Ethernet is on the order of 2500 m.

Ethernet Transmitter Algorithm

- Once an adaptor has detected a collision, and stopped its transmission, it waits a certain amount of time and tries again.
- Each time the adaptor tries to transmit but fails, it doubles the amount of time it waits before trying again.
- This strategy of doubling the delay interval between each retransmission attempt is known as *Exponential Backoff*.

Ethernet Transmitter Algorithm

- The adaptor first delays either 0 or 51.2 μs , selected at random.
- If this effort fails, it then waits 0, 51.2, 102.4, 153.6 μs (selected randomly) before trying again;
 - This is $k * 51.2$ for $k = 0, 1, 2, 3$
- After the third collision, it waits $k * 51.2$ for $k = 0 \dots 2^3 - 1$ (again selected at random).
- In general, the algorithm randomly selects a k between 0 and $2^n - 1$ and waits for $k * 51.2 \mu\text{s}$, where n is the number of collisions experienced so far.

Experience with Ethernet

- Ethernets work best under lightly loaded conditions.
 - Under heavy loads, too much of the network's capacity is wasted by collisions.
- Most Ethernets are used in a conservative way.
 - Have fewer than 200 hosts connected to them which is far fewer than the maximum of 1024.
- Most Ethernets are far shorter than 2500m with a round-trip delay of closer to 5 μ s than 51.2 μ s.
- Ethernets are easy to administer and maintain.
 - There are no switches that can fail and no routing and configuration tables that have to be kept up-to-date.
 - It is easy to add a new host to the network.
 - It is inexpensive.
 - Cable is cheap, and only other cost is the network adaptor on each host.

Wireless Links

- Wireless links transmit electromagnetic signals
 - Radio, microwave, infrared
- Wireless links all share the same “wire” (so to speak)
 - The challenge is to share it efficiently without unduly interfering with each other
 - Most of this sharing is accomplished by dividing the “wire” along the dimensions of frequency and space
- Exclusive use of a particular frequency in a particular geographic area may be allocated to an individual entity such as a corporation

Wireless Links

- These allocations are determined by government agencies such as FCC (Federal Communications Commission) in USA
- Specific bands (frequency) ranges are allocated to certain uses.
 - Some bands are reserved for government use
 - Other bands are reserved for uses such as AM radio, FM radio, televisions, satellite communications, and cell phones
 - Specific frequencies within these bands are then allocated to individual organizations for use within certain geographical areas.
 - Finally, there are several frequency bands set aside for “license exempt” usage
 - Bands in which a license is not needed

Wireless Links

- Devices that use license-exempt frequencies are still subject to certain restrictions
 - The first is a limit on transmission power
 - This limits the range of signal, making it less likely to interfere with another signal
 - For example, a cordless phone might have a range of about 100 feet.

Wireless Links

- The second restriction requires the use of **Spread Spectrum** technique
 - Idea is to spread the signal over a wider frequency band
 - So as to minimize the impact of interference from other devices
 - Originally designed for military use
 - ***Frequency hopping***
 - Transmitting signal over a random sequence of frequencies
 - First transmitting at one frequency, then a second, then a third...
 - The sequence of frequencies is not truly random, instead computed algorithmically by a pseudorandom number generator
 - The receiver uses the same algorithm as the sender, initializes it with the same seed, and is
 - Able to hop frequencies in sync with the transmitter to correctly receive the frame

Wireless Links

- A second spread spectrum technique called ***Direct sequence***
 - Represents each bit in the frame by multiple bits in the transmitted signal.
 - For each bit the sender wants to transmit
 - It actually sends the exclusive OR of that bit and n random bits
 - The sequence of random bits is generated by a pseudorandom number generator known to both the sender and the receiver.
 - The transmitted values, known as an ***n -bit chipping code***, spread the signal across a frequency band that is n times wider

Wireless Links

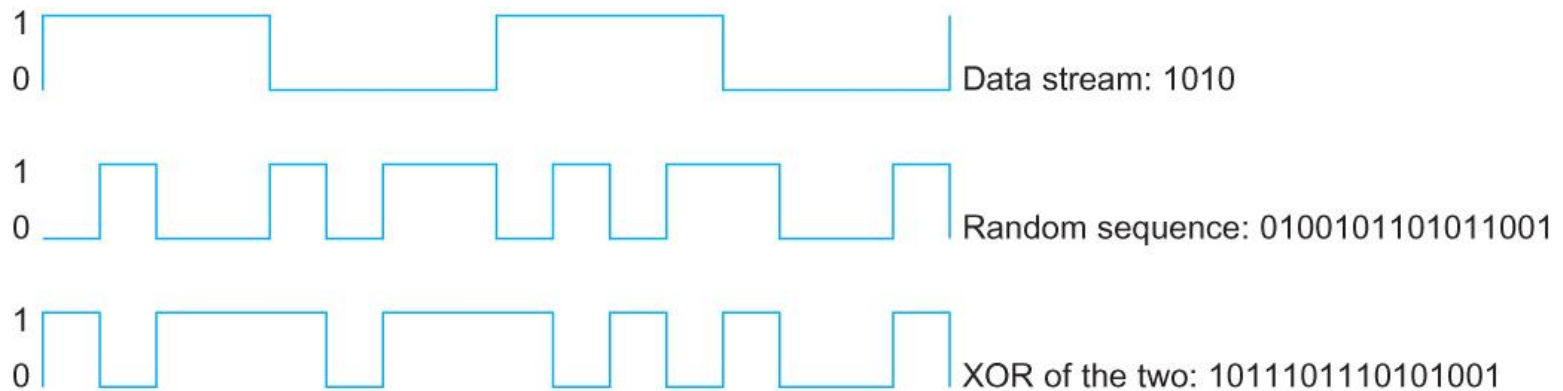

Example 4-bit chipping sequence

Wireless Links

- Wireless technologies differ in a variety of dimensions
 - How much bandwidth they provide
 - How far apart the communication nodes can be
- Four prominent wireless technologies
 - Bluetooth
 - Wi-Fi (more formally known as 802.11)
 - WiMAX (802.16)
 - 3G cellular wireless

Wireless Links

	Bluetooth (802.15.1)	Wi-Fi (802.11)	3G Cellular
Typical link length	10 m	100 m	Tens of kilometers
Typical data rate	2 Mbps (shared)	54 Mbps (shared)	Hundreds of kbps (per connection)
Typical use	Link a peripheral to a computer	Link a computer to a wired base	Link a mobile phone to a wired tower
Wired technology analogy	USB	Ethernet	DSL

Overview of leading wireless technologies

Wireless Links

- Mostly widely used wireless links today are usually asymmetric
 - Two end-points are usually different kinds of nodes
 - One end-point usually has no mobility, but has wired connection to the Internet (known as **base station**)
 - The node at the other end of the link is often mobile

Wireless Links

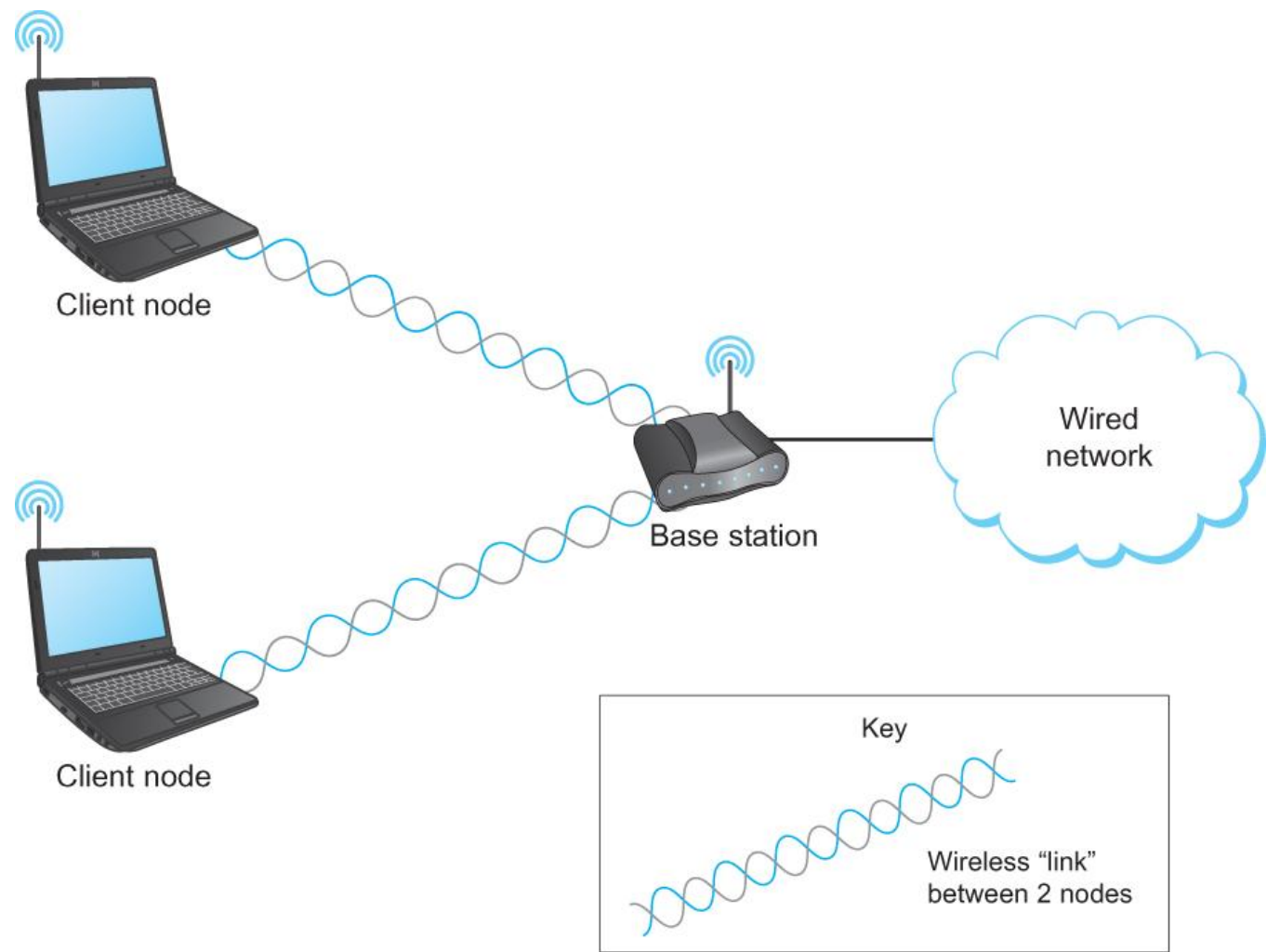

A wireless network using a base station

Wireless Links

- Wireless communication supports point-to-multipoint communication
- Communication between non-base (client) nodes is routed via the base station
- Three levels of mobility for clients
 - No mobility: the receiver must be in a fix location to receive a directional transmission from the base station (initial version of WiMAX)
 - Mobility is within the range of a base (Bluetooth)
 - Mobility between bases (Cell phones and Wi-Fi)

Wireless Links

- Mesh or Ad-hoc network
 - Nodes are peers
 - Messages may be forwarded via a chain of peer nodes

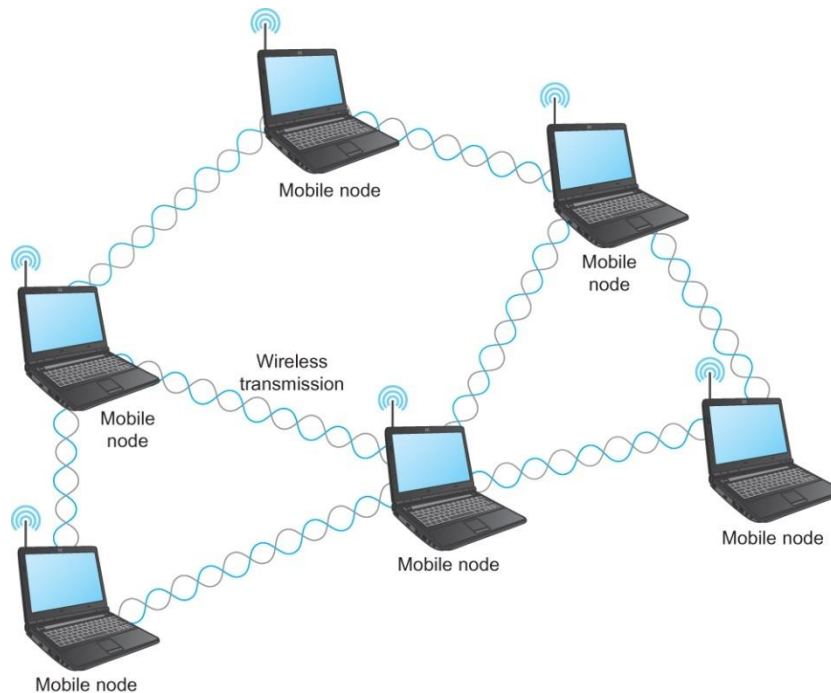

A wireless ad-hoc or mesh network

IEEE 802.11

- Also known as Wi-Fi
- Like its Ethernet and token ring siblings, 802.11 is designed for use in a limited geographical area (homes, office buildings, campuses)
 - Primary challenge is to mediate access to a shared communication medium – in this case, signals propagating through space
- 802.11 supports additional features
 - power management and
 - security mechanisms

IEEE 802.11

- Original 802.11 standard defined two radio-based physical layer standard
 - One using the frequency hopping
 - Over 79 1-MHz-wide frequency bandwidths
 - Second using direct sequence
 - Using 11-bit chipping sequence
 - Both standards run in the 2.4-GHz and provide up to 2 Mbps
- Then physical layer standard 802.11b was added
 - Using a variant of direct sequence 802.11b provides up to 11 Mbps
 - Uses license-exempt 2.4-GHz band
- Then came 802.11a which delivers up to 54 Mbps using OFDM
 - 802.11a runs on license-exempt 5-GHz band
- Most recent standard is 802.11g which is backward compatible with 802.11b
 - Uses 2.4 GHz band, OFDM and delivers up to 54 Mbps

IEEE 802.11 – Collision Avoidance

- Consider the situation in the following figure where each of four nodes is able to send and receive signals that reach just the nodes to its immediate left and right
 - For example, B can exchange frames with A and C, but it cannot reach D
 - C can reach B and D but not A

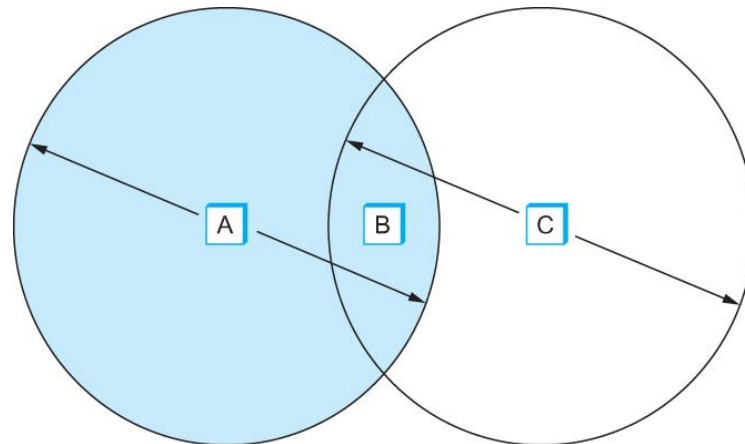

Example of a wireless network

IEEE 802.11 – Collision Avoidance

- Suppose both A and C want to communicate with B and so they each send it a frame.
 - A and C are unaware of each other since their signals do not carry that far
 - These two frames collide with each other at B
 - But unlike an Ethernet, neither A nor C is aware of this collision
 - A and C are said to *hidden nodes* with respect to each other

IEEE 802.11 – Collision Avoidance

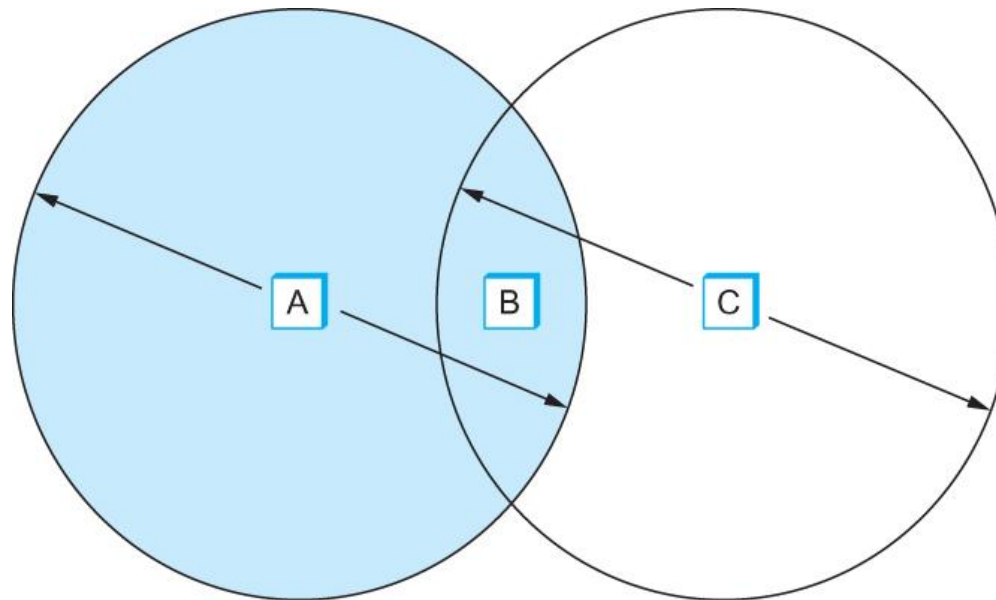

The “Hidden Node” Problem. Although A and C are hidden from each other, their signals can collide at B. (B’s reach is not shown.)

IEEE 802.11 – Collision Avoidance

- Another problem called *exposed node* problem occurs
 - Suppose B is sending to A. Node C is aware of this communication because it hears B's transmission.
 - It would be a mistake for C to conclude that it cannot transmit to anyone just because it can hear B's transmission.
 - Suppose C wants to transmit to node D.
 - This is not a problem since C's transmission to D will not interfere with A's ability to receive from B.

IEEE 802.11 – Collision Avoidance

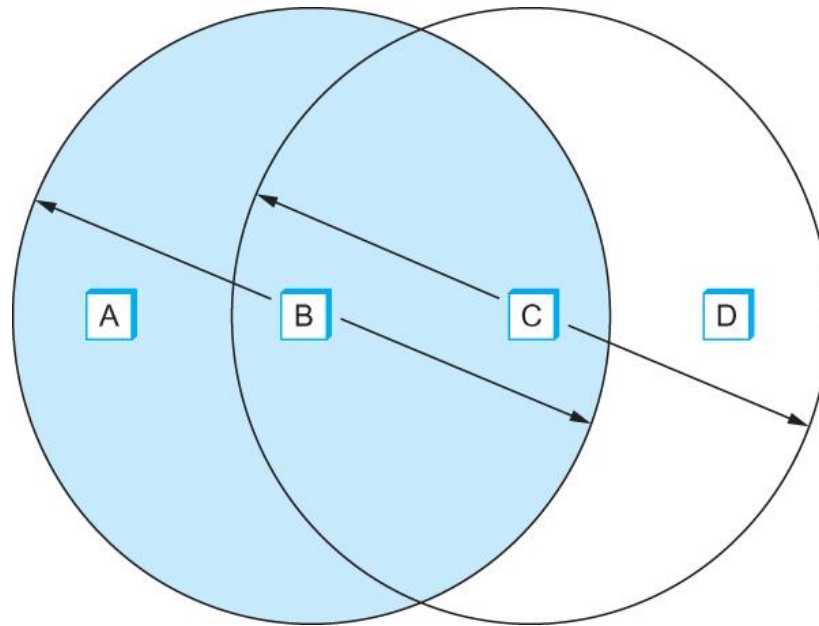

Exposed Node Problem. Although B and C are exposed to each other's signals, there is no interference if B transmits to A while C transmits to D. (A and D's reaches are not shown.)

IEEE 802.11 – Collision Avoidance

- 802.11 addresses these two problems with an algorithm called Multiple Access with Collision Avoidance (MACA).
- Key Idea
 - Sender and receiver exchange control frames with each other before the sender actually transmits any data.
 - This exchange informs all nearby nodes that a transmission is about to begin
 - Sender transmits a *Request to Send (RTS)* frame to the receiver.
 - The RTS frame includes a field that indicates how long the sender wants to hold the medium
 - Length of the data frame to be transmitted
 - Receiver replies with a *Clear to Send (CTS)* frame
 - This frame echoes this length field back to the sender

IEEE 802.11 – Collision Avoidance

- Any node that sees the CTS frame knows that
 - it is close to the receiver, therefore
 - cannot transmit for the period of time it takes to send a frame of the specified length
- Any node that sees the RTS frame but not the CTS frame
 - is not close enough to the receiver to interfere with it, and
 - so is free to transmit

IEEE 802.11 – Collision Avoidance

- Using ACK in MACA
 - Proposed in MACAW: MACA for Wireless LANs
- Receiver sends an ACK to the sender after successfully receiving a frame
- All nodes must wait for this ACK before trying to transmit
- If two or more nodes detect an idle link and try to transmit an RTS frame at the same time
 - Their RTS frame will collide with each other
- 802.11 does not support collision detection
 - So the senders realize the collision has happened when they do not receive the CTS frame after a period of time
 - In this case, they each wait a random amount of time before trying again.
 - The amount of time a given node delays is defined by the same *exponential backoff* algorithm used on the Ethernet.

IEEE 802.11 – Distribution System

- 802.11 is suitable for an ad-hoc configuration of nodes that may or may not be able to communicate with all other nodes.
- Nodes are free to move around
- The set of directly reachable nodes may change over time
- To deal with this mobility and partial connectivity,
 - 802.11 defines additional structures on a set of nodes
 - Instead of all nodes being created equal,
 - some nodes are allowed to roam
 - some are connected to a wired network infrastructure
 - they are called *Access Points (AP)* and they are connected to each other by a so-called *distribution system*

IEEE 802.11 – Distribution System

- Following figure illustrates a distribution system that connects three access points, each of which services the nodes in the same region
- Each of these regions is analogous to a cell in a cellular phone system with the APIs playing the same role as a base station
- The distribution network runs at layer 2 of the ISO architecture

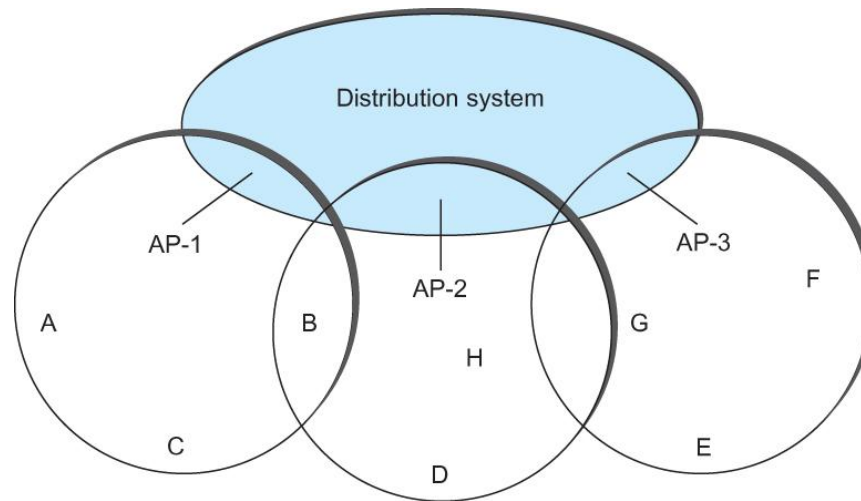

Access points connected to a distribution network

IEEE 802.11 – Distribution System

- Although two nodes can communicate directly with each other if they are within reach of each other, the idea behind this configuration is
 - Each nodes associates itself with one access point
 - For node A to communicate with node E, A first sends a frame to its AP-1 which forwards the frame across the distribution system to AP-3, which finally transmits the frame to E

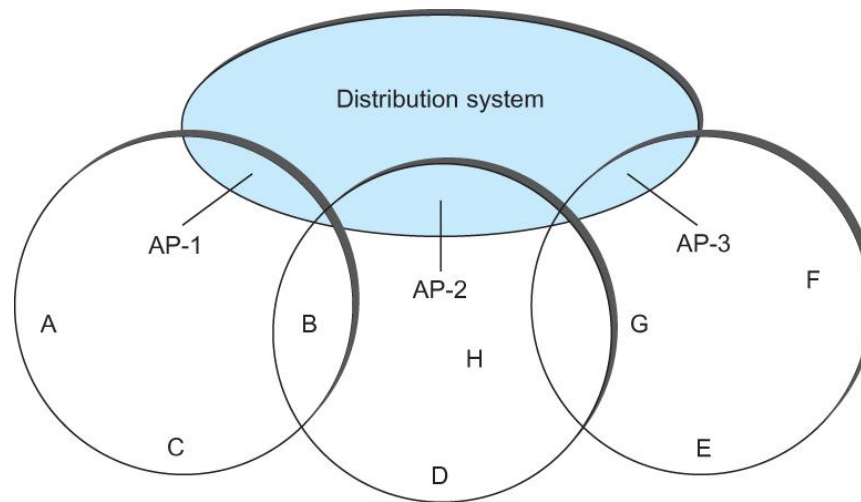

Access points connected to a distribution network

IEEE 802.11 – Distribution System

- How do the nodes select their access points
- How does it work when nodes move from one cell to another
- The technique for selecting an AP is called *scanning*
 - The node sends a *Probe* frame
 - All APs within reach reply with a *Probe Response* frame
 - The node selects one of the access points and sends that AP an *Association Request* frame
 - The AP replies with an *Association Response* frame
- A node engages this protocol whenever
 - it joins the network, as well as
 - when it becomes unhappy with its current AP
 - This might happen, for example, because the signal from its current AP has weakened due to the node moving away from it
 - Whenever a node acquires a new AP, the new AP notifies the old AP of the change via the distribution system

IEEE 802.11 – Distribution System

- Consider the situation shown in the following figure when node C moves from the cell serviced by AP-1 to the cell serviced by AP-2.
- As it moves, it sends *Probe* frames, which eventually result in *Probe Responses* from AP-2.
- At some point, C prefers AP-2 over AP-1, and so it associates itself with that access point.
 - This is called *active scanning* since the node is actively searching for an access point

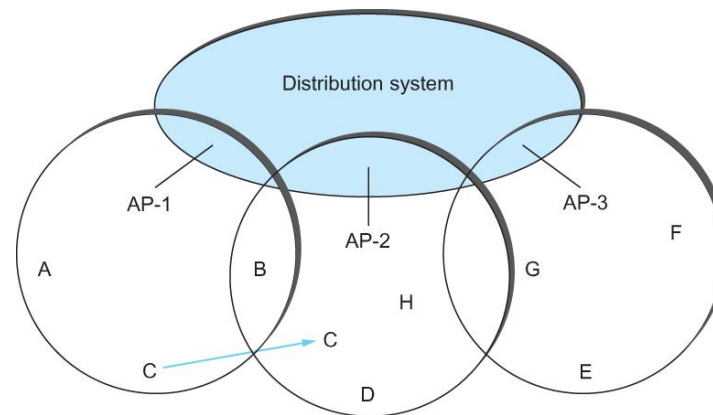

Node Mobility

IEEE 802.11 – Distribution System

- APs also periodically send a *Beacon* frame that advertises the capabilities of the access point; these include the transmission rate supported by the AP
 - This is called *passive scanning*
 - A node can change to this AP based on the *Beacon* frame simply by sending it an *Association Request* frame back to the access point.

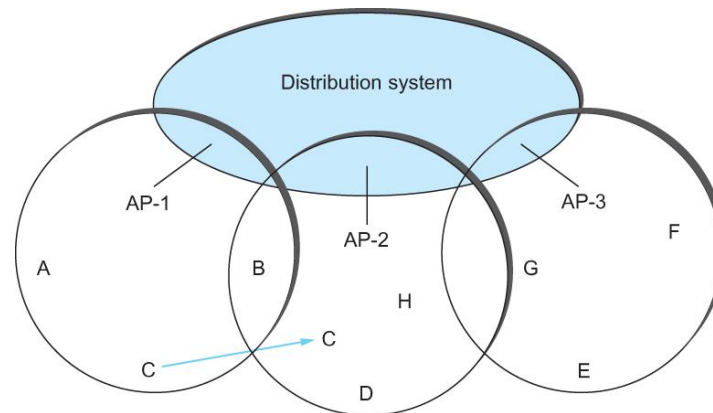

Node Mobility

IEEE 802.11 – Frame Format

- Source and Destinations addresses: each 48 bits
- Data: up to 2312 bytes
- CRC: 32 bit
- Control field: 16 bits
 - Contains three subfields (of interest)
 - 6 bit **Type** field: indicates whether the frame is an RTS or CTS frame or being used by the scanning algorithm
 - A pair of 1 bit fields : called **ToDS** and **FromDS**



Frame Format

IEEE 802.11 – Frame Format

- Frame contains four addresses
- How these addresses are interpreted depends on the settings of the **ToDS** and **FromDS** bits in the frame's Control field
- This is to account for the possibility that the frame had to be forwarded across the distribution system which would mean that,
 - the original sender is not necessarily the same as the most recent transmitting node
- Same is true for the destination address
- Simplest case
 - When one node is sending directly to another, both the DS bits are 0, Addr1 identifies the target node, and Addr2 identifies the source node

IEEE 802.11 – Frame Format

- Most complex case
 - Both DS bits are set to 1
 - Indicates that the message went from a wireless node onto the distribution system, and then from the distribution system to another wireless node
 - With both bits set,
 - Addr1 identifies the ultimate destination,
 - Addr2 identifies the immediate sender (the one that forwarded the frame from the distribution system to the ultimate destination)
 - Addr3 identifies the intermediate destination (the one that accepted the frame from a wireless node and forwarded across the distribution system)
 - Addr4 identifies the original source

- Addr1: E, Addr2: AP-3, Addr3: AP-1, Addr4: A

Bluetooth

- Used for very short range communication between mobile phones, PDAs, notebook computers and other personal or peripheral devices
- Operates in the license-exempt band at 2.45 GHz
- Has a range of only 10 m
- Communication devices typically belong to one individual or group
 - Sometimes categorized as Personal Area Network (PAN)
- Version 2.0 provides speeds up to 2.1 Mbps
- Power consumption is low

Bluetooth

- Bluetooth is specified by an industry consortium called the Bluetooth Special Interest Group
- It specifies an entire suite of protocols, going beyond the link layer to define application protocols, which it calls *profiles*, for a range of applications
 - There is a profile for synchronizing a PDA with personal computer
 - Another profile gives a mobile computer access to a wired LAN
- The basic Bluetooth network configuration is called a *piconet*
 - Consists of a master device and up to seven slave devices
 - Any communication is between the master and a slave
 - The slaves do not communicate directly with each other
 - A slave can be *parked*: set to an inactive, low-power state

Bluetooth

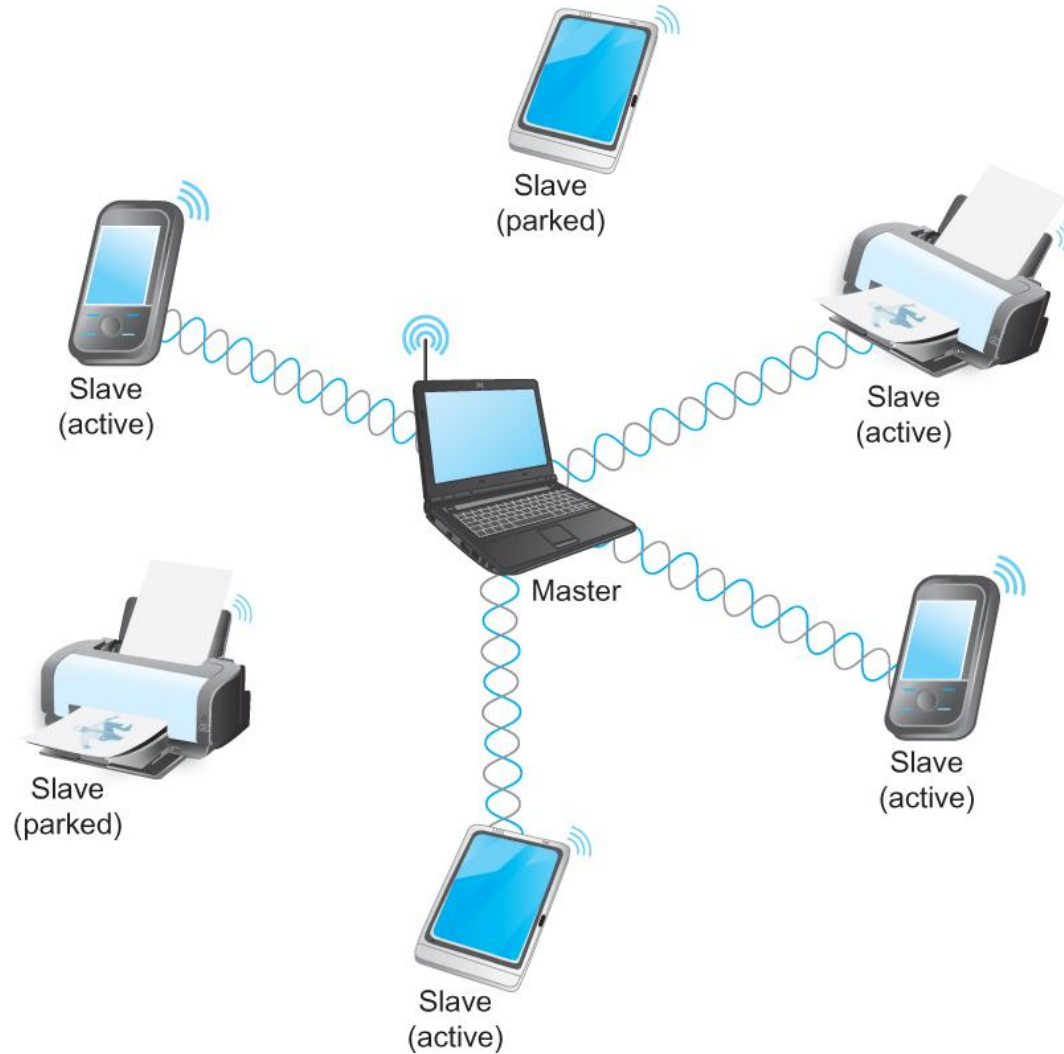

A Bluetooth Piconet

ZigBee

- ZigBee is a new technology that competes with Bluetooth
- Devised by the ZigBee alliance and standardized as IEEE 802.15.4
- It is designed for situations where the bandwidth requirements are low and power consumption must be very low to give very long battery life
- It is also intended to be simpler and cheaper than Bluetooth, making it financially feasible to incorporate in cheaper devices such as a wall switch that wirelessly communicates with a ceiling-mounted fan

Summary

- We introduced the many and varied type of links that are used to connect users to existing networks, and to construct large networks from scratch.
- We looked at the five key issues that must be addressed so that two or more nodes connected by some medium can exchange messages with each other
 - Encoding
 - Framing
 - Error Detecting
 - Reliability
 - Multiple Access Links
 - Ethernet
 - Wireless 802.11, Bluetooth